

# OPM-MEG, SQUID-MEG, and EEG dataset

## Reference Manual

ver.1 2020/10/30

ver.2 2023/03/01

Department of Computational Brain Imaging,  
ATR Neural Information Analysis Laboratories

## Table of Contents

<b>Introduction .....</b>	<b>3</b>
<b>Subjects .....</b>	<b>3</b>
<b>Tasks .....</b>	<b>4</b>
<b>Motor task.....</b>	<b>4</b>
<b>Auditory task.....</b>	<b>4</b>
<b>Somatosensory task.....</b>	<b>4</b>
<b>Resting-state task .....</b>	<b>4</b>
<b>Recordings.....</b>	<b>4</b>
<b>OPM-MEG .....</b>	<b>4</b>
<b>SQUID-MEG and EEG .....</b>	<b>6</b>
<b>T1-weighted image.....</b>	<b>7</b>
<b>Data .....</b>	<b>8</b>
<b>Directory structure.....</b>	<b>8</b>
<b>OPM-MEG data .....</b>	<b>8</b>
<b>SQUID-MEG data.....</b>	<b>8</b>
<b>EEG data.....</b>	<b>9</b>
<b>T1-weighted image.....</b>	<b>9</b>
<b>Acknowledgment.....</b>	<b>9</b>

## Introduction

This document introduces the OPM-MEG, SQUID-MEG, and EEG (OSE) dataset, which aims to disseminate a new type of magnetoencephalography (MEG) device, an optically pumped magnetometer (OPM). This dataset will provide OPM-MEG, SQUID-MEG, and electroencephalography (EEG) data during four typical tasks.

Brain activities of five subjects were recorded with the following three modalities:

- OPM-MEG
- SQUID-MEG
- EEG

while they performed the following four tasks:

- Motor
- Auditory
- Somatosensory
- Resting-state.

Furthermore, their brain structures were measured with

- T1-weighted images.

## Subjects

- Five healthy subjects (Table 1) participated in all the experiments. All gave written informed consent for the experimental procedures, which were approved by the ATR Human Subject Review Committee. All had normal or corrected-to-normal visual acuity.
- Note: Subject 095 does not have OPM-MEG data.

Subject ID	Age	Sex	Dominant hand
002	43	Male	Right
005	42	Male	Left
006	43	Male	Right
093	25	Male	Right
095	26	Male	Right

Table 1. Subject information.

## Tasks

### Motor task

The subjects fixated on a cross and extended their right middle fingers once about every three seconds. Each run's length was about 5 min.

### Auditory task

A pure tone of 0.1-sec duration was repeatedly presented binaurally while the subjects closed their eyes for about 7 min. The inter-stimulus intervals (ISIs) were about 1.7 sec.

### Somatosensory task

Electrical stimulation of 0.2-msec duration was repeatedly presented to the subjects' right median nerves while they closed their eyes for about 5 min. The ISIs were about 1.7 sec.

### Resting-state task

The subjects fixated on a cross for 5 min.

## Recordings

### OPM-MEG

For the OPM-MEG recordings, fifteen OPM sensors (ten QZFM Gen-2, five QZFM Gen-3, QuSpin Inc., U.S.) were used by mounting the head cap (Fig. 1). Each sensor records the z and y-axis (30 channels). The sampling frequency was 2 kHz. Because OPM-MEG measurement requires a relatively low magnetic field environment, a magnetic field canceling coil was installed in the magnetically shielded room. It controlled the magnetic field around the subject's head to less than 1 nT. During the recordings, the subject's head was fixed on the chin rest to suppress the head motion.

Horizontal and vertical axes of electrooculogram (EOG) were recorded simultaneously with a sampling frequency of 1 kHz. In the motor task, an electromyogram (EMG) was recorded to be used as a stimulus onset signal.

OPM-MEG and EOG data were converted to the VBMEG format (.meg.mat, .eeg.mat).



Figure 1. OPM-MEG recording.

Sync signals, stimulus onsets, the EOG, and the EMG were stored in the following channels.

Motor				
Subject	Sync signal (MEG)	Sync signal (EOG)	EOG	EMG
002	sync_pulse	EXT1	Ch1, 2	trigger_emg (MEG)
005	sync_pulse	EXT1	Ch1, 2	trigger_emg (MEG)
006	sync_pulse	EXT1	Ch1, 2	trigger_emg (MEG)
093	sync_pulse	EXT1	Ch1, 2	trigger_emg (MEG)

Auditory			
Subject	Stim. onset (MEG)	Stim. onset (EOG)	EOG
002	trigger_pulse	EXT1	Ch1, 2
005	trigger_pulse	EXT1	Ch1, 2
006	trigger_pulse	EXT1	Ch1, 2
093	trigger_pulse	EXT1	Ch1, 2

Somatosensory			
Subject	Stim. onset (MEG)	Stim. onset (EOG)	EOG
002	trigger_pulse	EXT1	Ch1, 2
005	trigger_pulse	EXT1	Ch1, 2
006	trigger_pulse	EXT1	Ch1, 2
093	trigger_pulse	EXT1	Ch1, 2

Resting-state			
Subject	Sync signal (MEG)	Sync signal (EOG)	EOG
002	sync_pulse	EXT1	Ch1, 2
005	sync_pulse	EXT1	Ch1, 2
006	sync_pulse	EXT1	Ch1, 2
093	sync_pulse	EXT1	Ch1, 2

### SQUID-MEG and EEG

During the tasks, SQUID-MEG and EEG were simultaneously recorded with a whole-head 400-channel system (210-channel Axial and 190-channel Planar Gradiometers; PQ1400RM; Yokogawa Electric Co., Japan) and a whole-head 63-channel system (BrainAmp; Brain Products GmbH, Germany), respectively (Fig. 2). The sampling frequency was 1 kHz. EOG and EMG (in the motor task) were also simultaneously recorded.

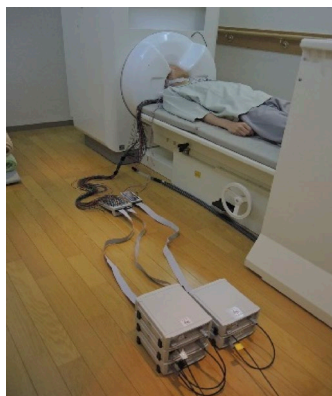

Figure 2. Simultaneous recording of SQUID-MEG and EEG.

Sync signals, stimulus onsets, the EOG, and the EMG were stored in the following channels.

Motor				
Subject	Sync signal (MEG)	Sync signal (EEG)	EOG	EMG
002	Ch435 (MEG)	run*.vmrk (EEG)	Ch64, 65 (EEG)	Ch416 (MEG)
005	Ch435 (MEG)	run*.vmrk (EEG)	Ch64, 65 (EEG)	Ch416 (MEG)
006	Ch435 (MEG)	run*.vmrk (EEG)	Ch64, 65 (EEG)	Ch416 (MEG)
093	Ch435 (MEG)	run*.vmrk (EEG)	Ch416, 417 (MEG)	Ch418 (MEG)

095	Ch435 (MEG)	run*.vmrk (EEG)	Ch64, 65 (EEG)	Ch416 (MEG)
-----	-------------	-----------------	----------------	-------------

Auditory			
Subject	Stim. onset (MEG)	Stim. onset (EEG)	EOG
002	Ch433 (MEG)	run*.vmrk (EEG)	Ch64, 65 (EEG)
005	Ch433 (MEG)	run*.vmrk (EEG)	Ch64, 65 (EEG)
006	Ch433 (MEG)	run*.vmrk (EEG)	Ch64, 65 (EEG)
093	Ch433 (MEG)	run*.vmrk (EEG)	Ch64, 65 (EEG)
095	Ch433 (MEG)	run*.vmrk (EEG)	Ch64, 65 (EEG)

Somatosensory			
Subject	Stim. onset (MEG)	Stim. onset (EEG)	EOG
002	Ch432 (MEG)	run*.vmrk (EEG)	Ch64, 65 (EEG)
005	Ch432 (MEG)	run*.vmrk (EEG)	Ch64, 65 (EEG)
006	Ch432 (MEG)	run*.vmrk (EEG)	Ch64, 65 (EEG)
093	Ch432 (MEG)	run*.vmrk (EEG)	Ch64, 65 (EEG)
095	Ch432 (MEG)	run*.vmrk (EEG)	Ch64, 65 (EEG)

Resting-state			
Subject	Sync signal (MEG)	Sync signal (EEG)	EOG
002	Ch435 (MEG)	run*.vmrk (EEG)	Ch64, 65 (EEG)
005	Ch435 (MEG)	run*.vmrk (EEG)	Ch64, 65 (EEG)
006	Ch435 (MEG)	run*.vmrk (EEG)	Ch64, 65 (EEG)
093	Ch435 (MEG)	run*.vmrk (EEG)	Ch416, 417 (MEG)
095	Ch435 (MEG)	run*.vmrk (EEG)	Ch64, 65 (EEG)

#### T1-weighted image

T1-weighted images were recorded using Three Tesla MR scanner (MAGNETOM Prisma, Siemens, Erlangen, Germany) with the following parameters: TR 2400 ms, TE 2.22 ms, TI 1000ms, Flip angle 8 deg., FOV 256 mm, Matrix 320x320, Thickness 0.8 mm, 256 slices.

## Data

### Directory structure

The data are stored in the following directory structure (Fig. 3).

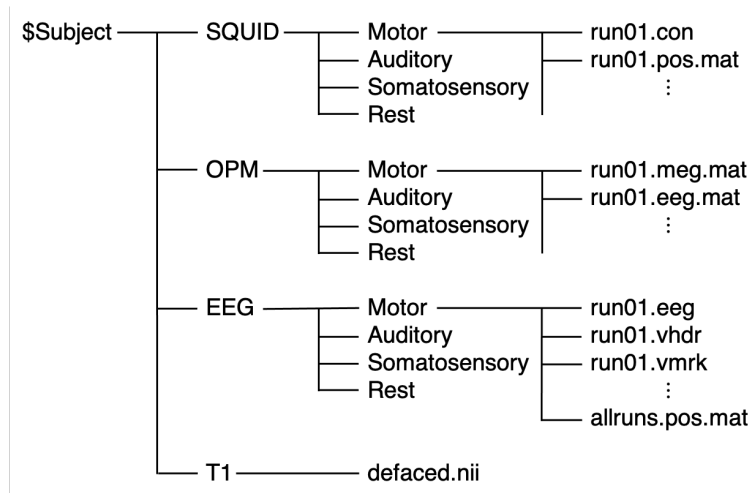

Figure 3. Directory structure.

\$Subject is 002, 005, 006, 093, or 095.

### OPM-MEG data

run\*.meg.mat contains the MEG signals, the position, and the orientation information of the MEG sensors in the VBMEG format.

run\*.eeg.mat contains the EOG signals in the VBMEG format.

### SQUID-MEG data

run\*.con contains the MEG signals.

run\*.pos.mat contains the position information of the MEG sensors and the transformation matrix of the MEG sensors to a RAS coordinate. In this coordinate, +x = right, +y = anterior, +z = superior and the origin [0 0 0] corresponds to the center of the T1-weighted image (\$SUBJECT/T1/defaced.nii).

Note that, for the subjects except for 093, Ch416 was defined as null although it was active.

Therefore, please modify its definition after importing the MEG file (run\*.con) if necessary.



#### EEG data

run\*.eeg contains the EEG signal.

run\*.vhdr contains the parameters of the EEG recording.

run\*.vmrk contains the time information of the sync signal and/or the stimulus onsets.

allruns.pos.mat contains the position information of the EEG sensors in the RAS coordinate, where +x = right, +y = anterior, +z = superior and the origin [0 0 0] corresponds to the center of the T1-weighted image (\$SUBJECT/T1/defaced.nii).

#### T1-weighted image

defaced.nii contains the defaced T1-weighted image.

#### Acknowledgment

This work was supported by a contract with the National Institute of Information and Communications Technology entitled “Analysis of multi-modal brain measurement data and development of its application for BMI open innovation” (209).